

**CCS Technical Documentation
RH-13 Series Transceivers**

**Assembly & Disassembly
Instructions**

Contents

	Page No
Assembling the RH-13 Transceiver	3
Exploded RH-13 Assembly	3
Step-by-Step Assembly Instructions	4
1. Insert Speaker (and gasket) to A-cover assembly	4
2. Insert Keymat to A-cover	4
3. Insert microphone to system connector	5
4. Insert LCD-module to PWB	5
5. Insert LCD / PWB assembly to A-cover	6
6. Insert D-cover assembly	6
7. Insert antenna	6
8. Insert screws	7
9. Insert antenna-cover to RH-13 assembly	7
10. Insert dust cap for rf-connector	8
Additional assembly instructions	8
1. Insert type label to metal deck	8
2. Insert battery to RH-13 assembly	9
3. Insert battery-cover to RH-13 assembly	9
4. Insert IR-window to A-cover assembly	10
Exploded D-cover assembly	10
Disassembling the RH-13 Transceiver	11
Preparation for Disassembly	11
Disassembly Tools	11
ESD Protection	11
Step-by-Step Disassembly Instructions	12
1. Remove battery-cover from Mozart assembly	12
2. Remove dust cap for rf-connector from antenna cover	12
3. Remove antenna-cover from Mozart assembly	12
4. Remove screws	13
5. Remove antenna	13
6. Remove D-cover assembly	13
7. Remove parts from D-cover assembly	14
8. Remove LCD / PWB assembly from A-cover	15
9. Remove LCD-module from PWB	15
10. Remove Keymat from A-cover	15
Additional disassembly instructions	16
1. Remove battery from Mozart assembly	16
2. Remove speaker and speaker gasket from A-cover	16
3. Remove IR-window from A-cover assembly	17
4. Remove LCD gasket from A-cover	17
5. Remove microphone from system connector	17

Assembling the RH-13 Transceiver

Exploded RH-13 Assembly

Figure 1: All parts and subassemblies of RH-13

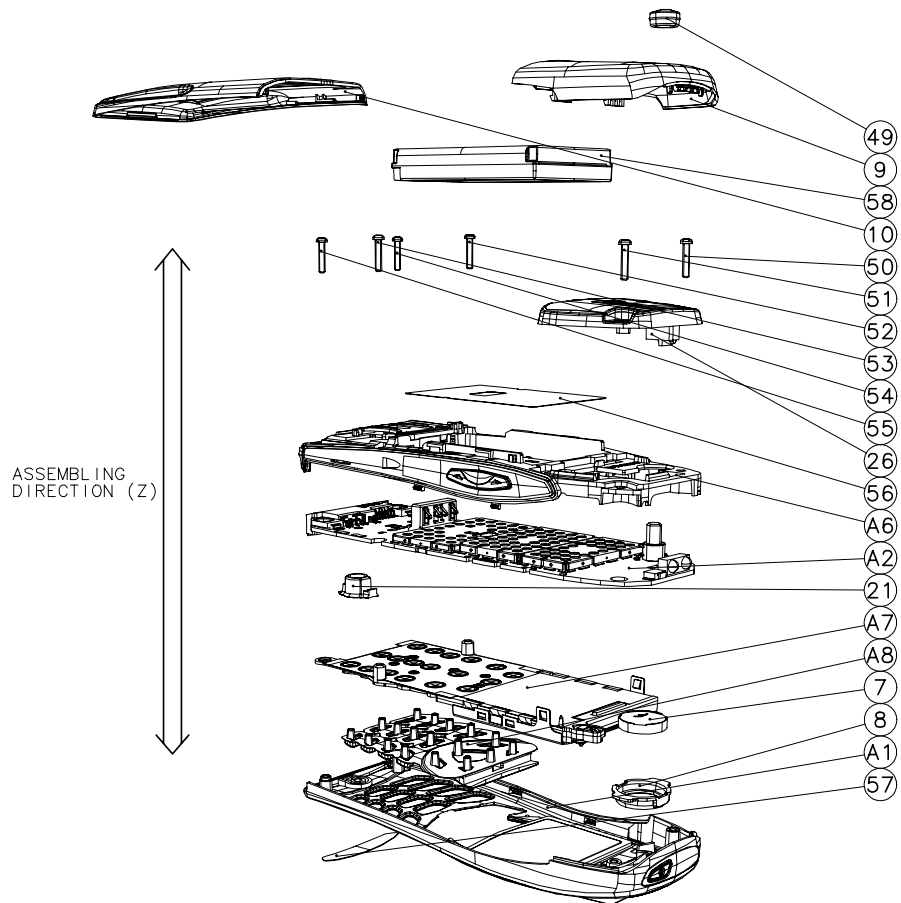

Step-by-Step Assembly Instructions

Wear cover gloves or finger covers and a wrist strap when assembling the phone.

1. Insert Speaker (and gasket) to A-cover assembly

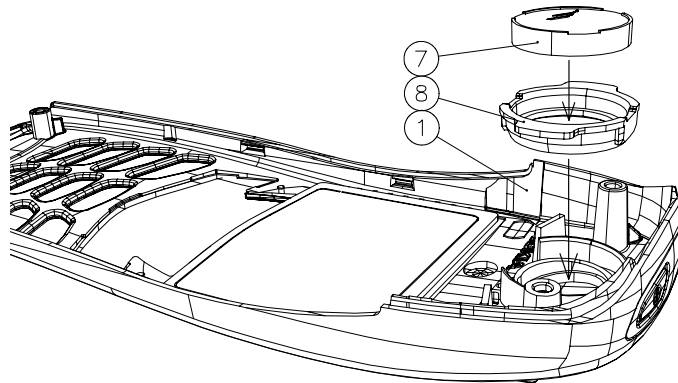

Insert a speaker and a gasket together before assembling to A-cover. Be careful with the speaker's springs.

Note: Alignment: Speaker gasket's "wings" towards A-cover's screwing towers.

2. Insert Keymat to A-cover

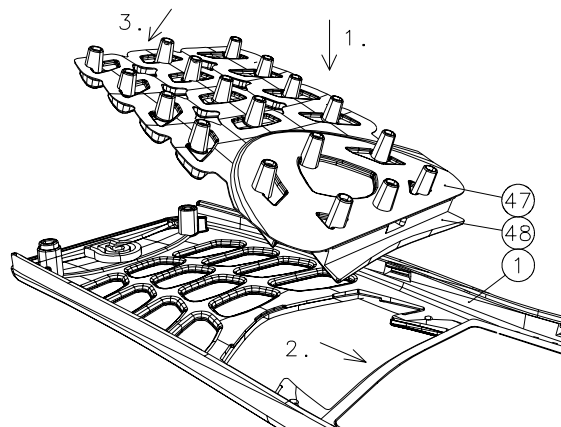

Follow steps 1-3 as shown in the figure. Pass the softkey (48) under the A-cover (1) flip. It is tight but it will pass. Focus key embosses to holes located in A-cover.

3. Insert microphone to system connector

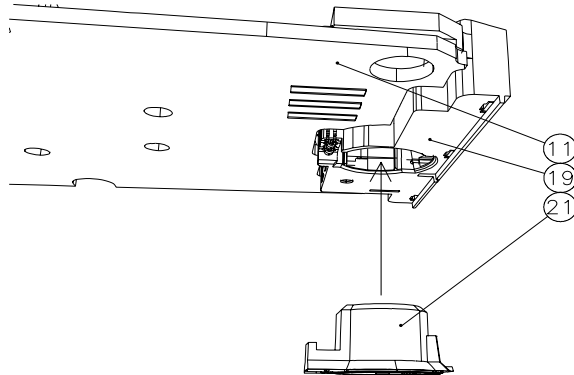

Look at the figure above carefully.

4. Insert LCD-module to PWB

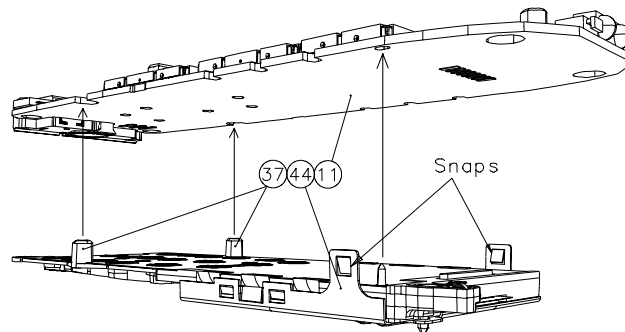

Remove the display cover tape first. The display "face" needs to be blown with ionized air before assembling. Focus pin at upper end of lightguide (37) to hole in PWB (11) and screw towers of lightguide to cutouts on edge of PWB.

LCD module is properly assembled when snaps joints in metal frame (44) clicks to PWB.

Blow module and A-cover with ionized air.

Note: Ensure that there is no debris on the window.

5. Insert LCD / PWB assembly to A-cover

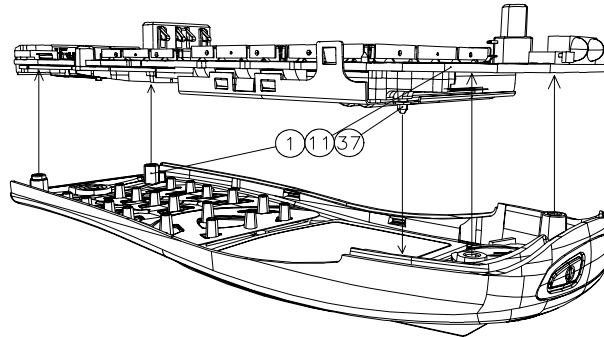

Before assembling LCD / PWB assembly to A-cover, check the placement of speaker assembly in A-cover. Screw towers in A-cover guides LCD / PWB assembly.

6. Insert D-cover assembly

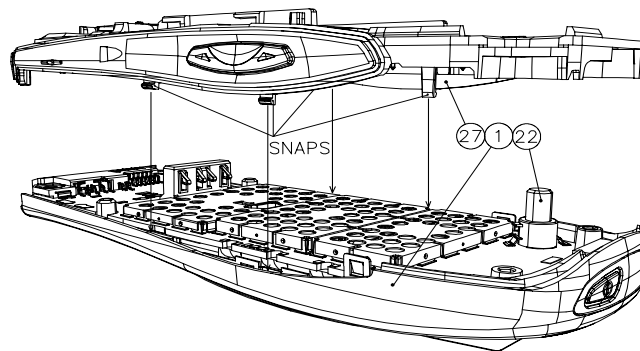

D-cover (27) is correctly inserted when you feel four snap joints clicking onto the A-cover (1). Push the D-cover assembly downwards quite hard. Be careful not to damage the springs of the battery connector by metal deck.

7. Insert antenna

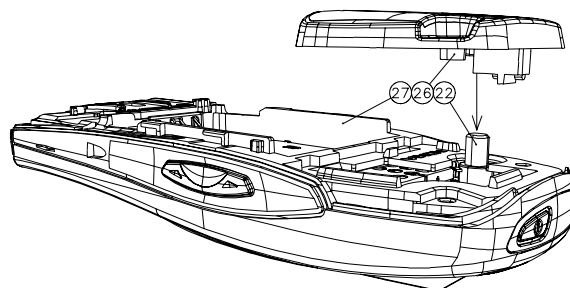

Wear gloves or rubber fingertips when handling the antenna (26). The antenna needs to undergo a visual inspection (flash, discoloration, etc) before assembling. Assembling guidance is in antenna connection to PWB (Rf-connector (22)).

8. Insert screws

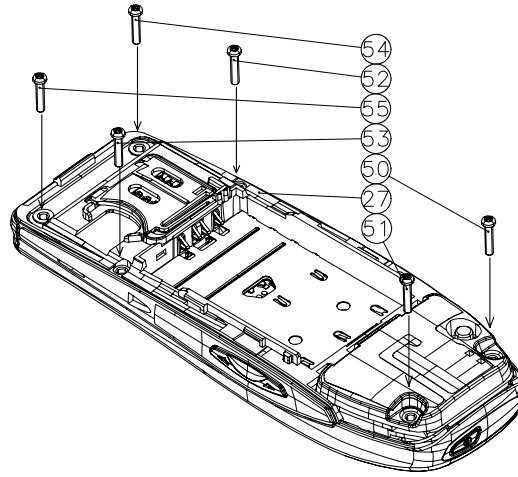

The estimated torque according to the screw trial for the all six screws is **22 Ncm** and speed of rotation **480 rpm** by using Torx+, 1.8x9 Deprag, automatic feeding 708U driver. Screwing order for pre-production is 50, 51, 52, 53, 54, and 55. Screwing order possibilities for testing purposes is limited to six (3!=3x2x1=6).

9. Insert antenna-cover to RH-13 assembly

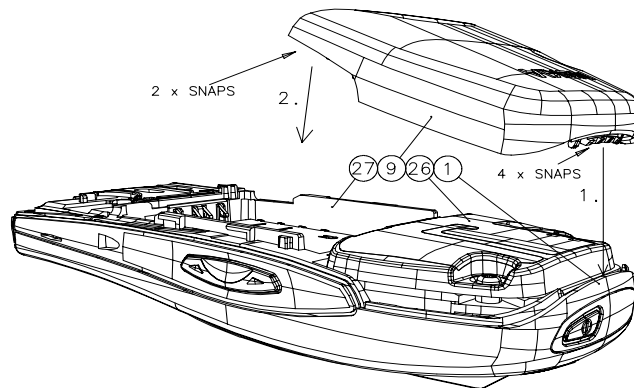

In step one, push the front end of the antenna cover downwards until it snaps from four snap joints in it. Be careful not to break them. Step two shows how to click the two lower and bigger snap joints last.

10. Insert dust cap for rf-connector

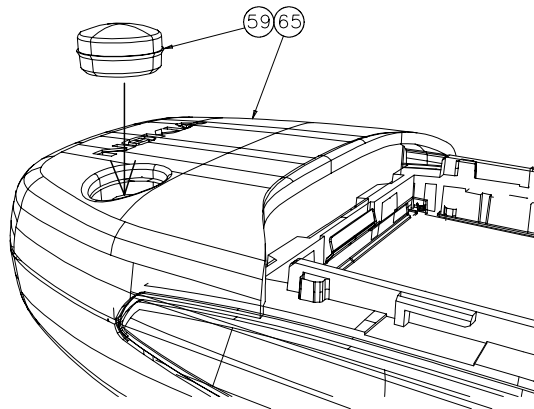

Push the dust cap downwards until it reaches the top surface of the antenna cover.

Additional assembly instructions

1. Insert type label to metal deck

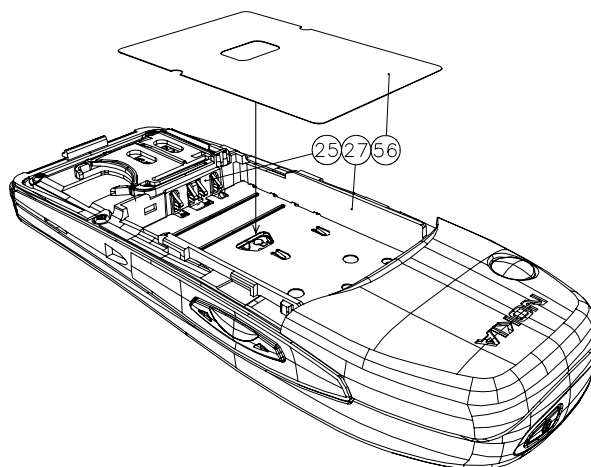

Focus type label (56) hole to hole located in metal deck (28).

2. Insert battery to RH-13 assembly

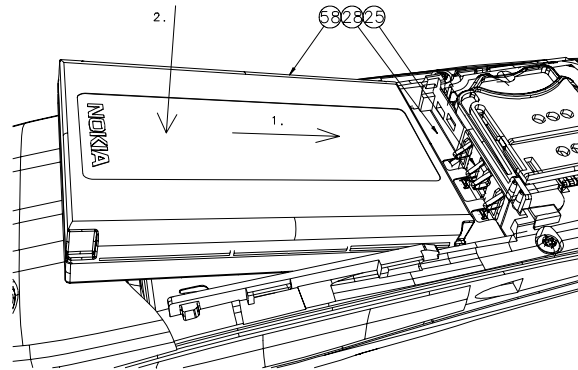

In step one, push the battery (58) against the springs of the battery connector (25).

In step two, push the battery from its front end downwards until it snaps onto the metal deck (28).

3. Insert battery-cover to RH-13 assembly

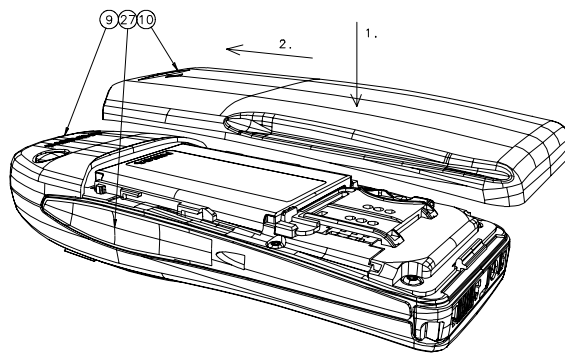

In step one, push the battery cover (10) downwards in the Z-direction until it hits the D-cover (27). In step two, push the battery cover towards the antenna cover (9) until it snaps from the front-end snap joint in it. Make sure all five (two on each side and one at the bottom end) bonding hooks of the battery cover are properly hooked.

4. Insert IR-window to A-cover assembly

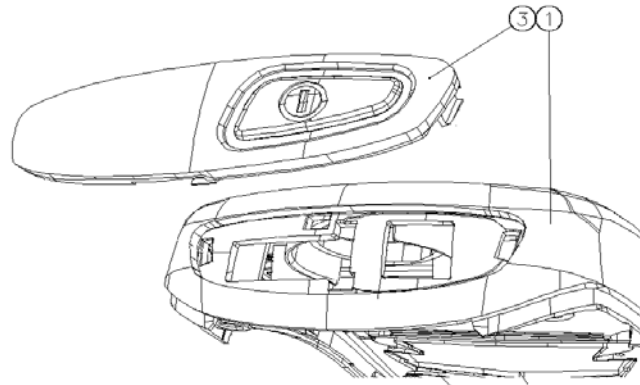

The IR-window is properly inserted when all four snaps are locked.

Exploded D-cover assembly

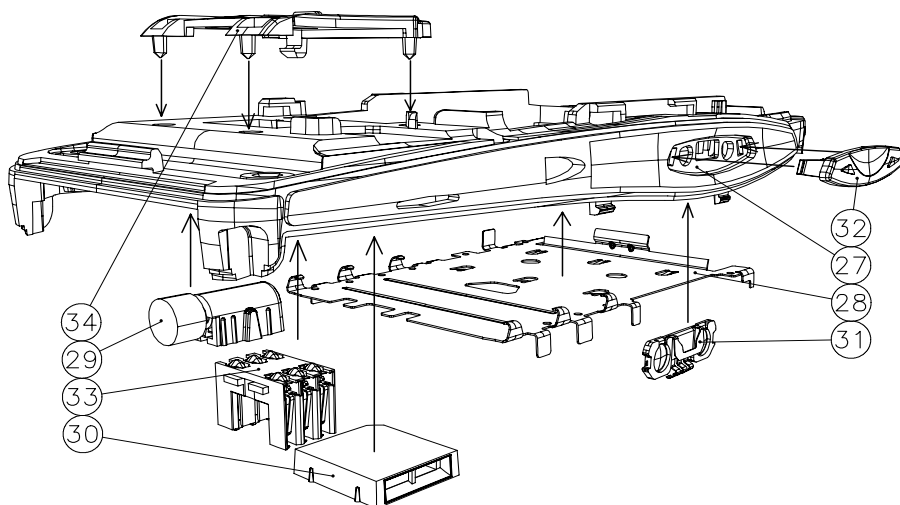

Insert volume key (32) before volume switch (31). Push metal deck (28) downwards from its sides near hooks until it snaps into D-cover (27). Push vibrator (29), SIM reader (33) and buzzer (30) into their places in D-cover. Check the correct position of SIM-Reader.

Heat stake SIM latch and metal deck using soldering iron, for example.

Disassembling the RH-13 Transceiver

Preparation for Disassembly

Disassembly Tools



Shown left to right: Torque-limiting screwdriver (torque set at 22N-cm), fiberglass soldering aid, and T6 Torx+ driver.

ESD Protection



ESD protection should be used when handling the PWB and other electronic components. The photo above shows a wrist strap, which can be grounded to a bench. This or some other form of ESD protection should be used when handling the phone.

Step-by-Step Disassembly Instructions

1. Remove battery-cover from Mozart assembly



Slide battery cover backwards in Y-direction while pushing hard from its middle front area using your thumb. Slide the battery cover long enough to release snap joints and hooks on sides of it.

2. Remove dust cap for rf-connector from antenna cover



Lift dust cap upwards from its hole using your fingernail or a screwdriver with a chisel point.

3. Remove antenna-cover from Mozart assembly



Release two snap joints one after another, first at the rear end of the cover. Use a screwdriver as a lever arm between the D-cover and the Antenna-cover.

4. Remove screws

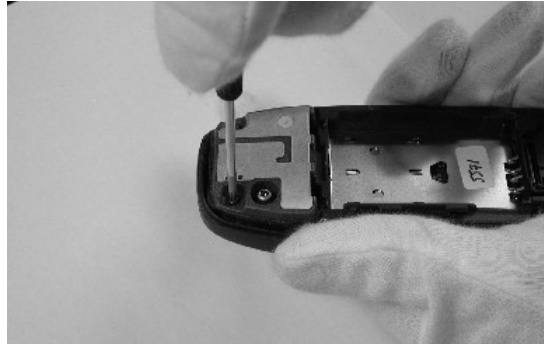

The estimated optimal torque for the all six screws is **22 Ncm** and the speed of rotation **480 rpm**. The unscrewing order for pre-production is in the reverse order to screwing; 55, 54, 53, 52, 51, and 50. The screwing order possibilities for testing purposes is limited to six ($3! = 3 \times 2 \times 1 = 6$).

5. Remove antenna

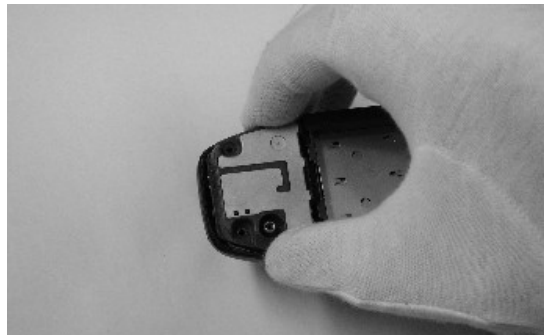

Wear gloves or rubber fingertips when handling the antenna.

6. Remove D-cover assembly

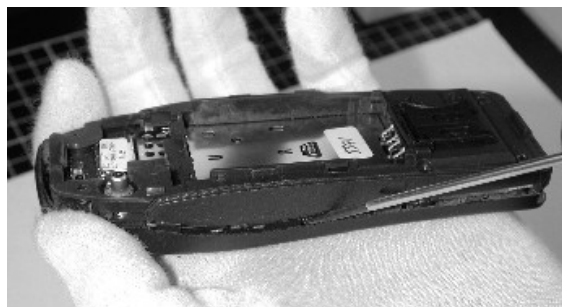

The D-cover is correctly removed when the four side snap joints of the D-cover are released from the A-cover. Use your fingernails or a screwdriver with a chisel point between the A and D-covers at the middle of the snap joint area to do the operation.

Note: Screwdriver must not hit the engine module or components on it during disassembly. Be also careful not to scratch covers.

On the next page you can see the removal operations of the subassemblies and parts of

the D-cover assembly.

7 ■ Remove parts from D-cover assembly

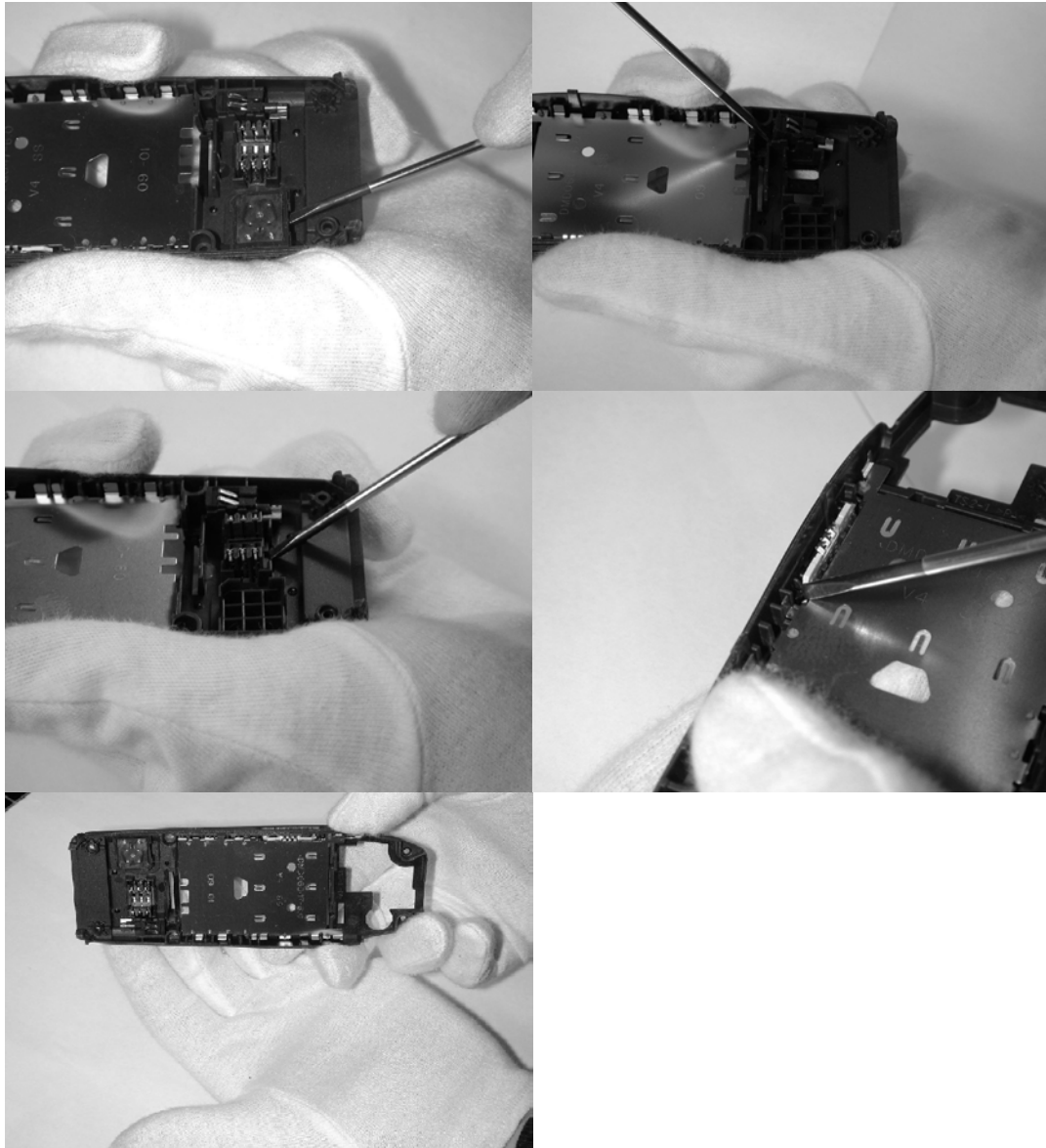

Lift vibrator, SIM reader and buzzer out of their slots of D-cover using screwdriver with chisel point or your fingertips. Release both snap joints of volume key before disassembling volume switch.

8. Remove LCD / PWB assembly from A-cover

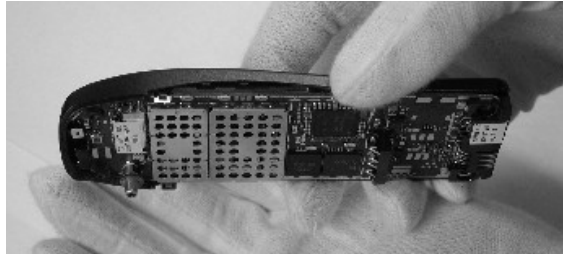

Screw towers in A-cover guides LCD / PWB assembly.

Note: Gloves and ESD protection are mandatory in this phase of disassembly to prevent fingerprints and damage in engine.

9. Remove LCD-module from PWB

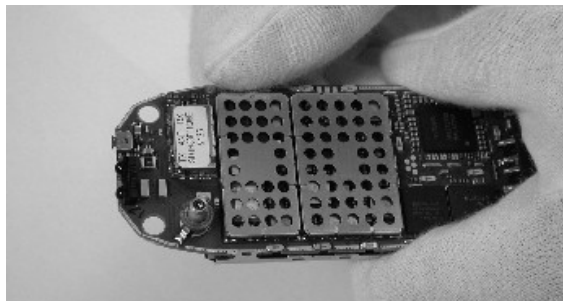

LCD module is properly disassembled when two snaps joints in metal frame are released from PWB.

Note: Gloves are mandatory if LCD-module will be reused. Also use ionized air for clean dirt from LCD before assembling it back to A-cover. Handle the elastomer connector with care.

10. Remove Keymat from A-cover



Lift keymat upwards from its rear end first. Then slide softkey away from its recess.

Additional disassembly instructions

1. Remove battery from Mozart assembly



Option 1: Lift battery upwards from its front end first by using screwdriver or your fingertip.

Option 2: Use your palm as a cup while hitting phone slightly towards the cup, battery side down.

2. Remove speaker and speaker gasket from A-cover



Remove speaker and gasket by lifting from gasket using screwdriver or your fingertip.

Note: Do not touch the springs of speaker as they can be damaged.

3. Remove IR-window from A-cover assembly



Start with snap joint at the middle of IR-lens by pushing it with screw driver with chisel point. There are four snap joints altogether.

4. Remove LCD gasket from A-cover



Tear gasket off from A-cover starting from the corner shown in figure above.

5. Remove microphone from system connector

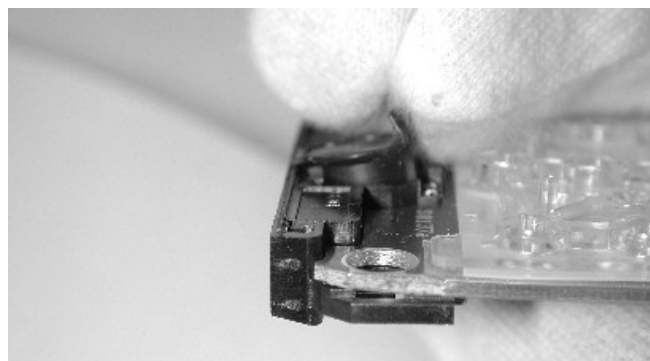

Lift microphone and gasket out from system connector.

This page intentionally left blank.